

Pos.	descrizione	Qta'
1	Telaio	1
2	Esagonale 8x45	1
4	Parattacco	1
5	Svasate 5x12	2
6	Distanziale D24 L7 foro8,5	1
7	Rondella 8	1
8	Leva cambio	1
9	Cuscinetto D22 L7 F8	1
10	Segger I22	1
11	Rondella T02	1
12	Poggiapiede	1
13	Tappo nylon	1
14	Tonda 6x35	1
15	Distanziale D10 L10 foro6,5	1
16	Nottolino x gommino	1
17	Gommino	1
18	Svasata 6x20	1
19	Testa snodata maschio DX	1
20	Dado M6 DX	1
21	Asta cambio femmina L=200	1
22	Ribassate 8x25	2
23	Dado M6 autobloccante rib	1

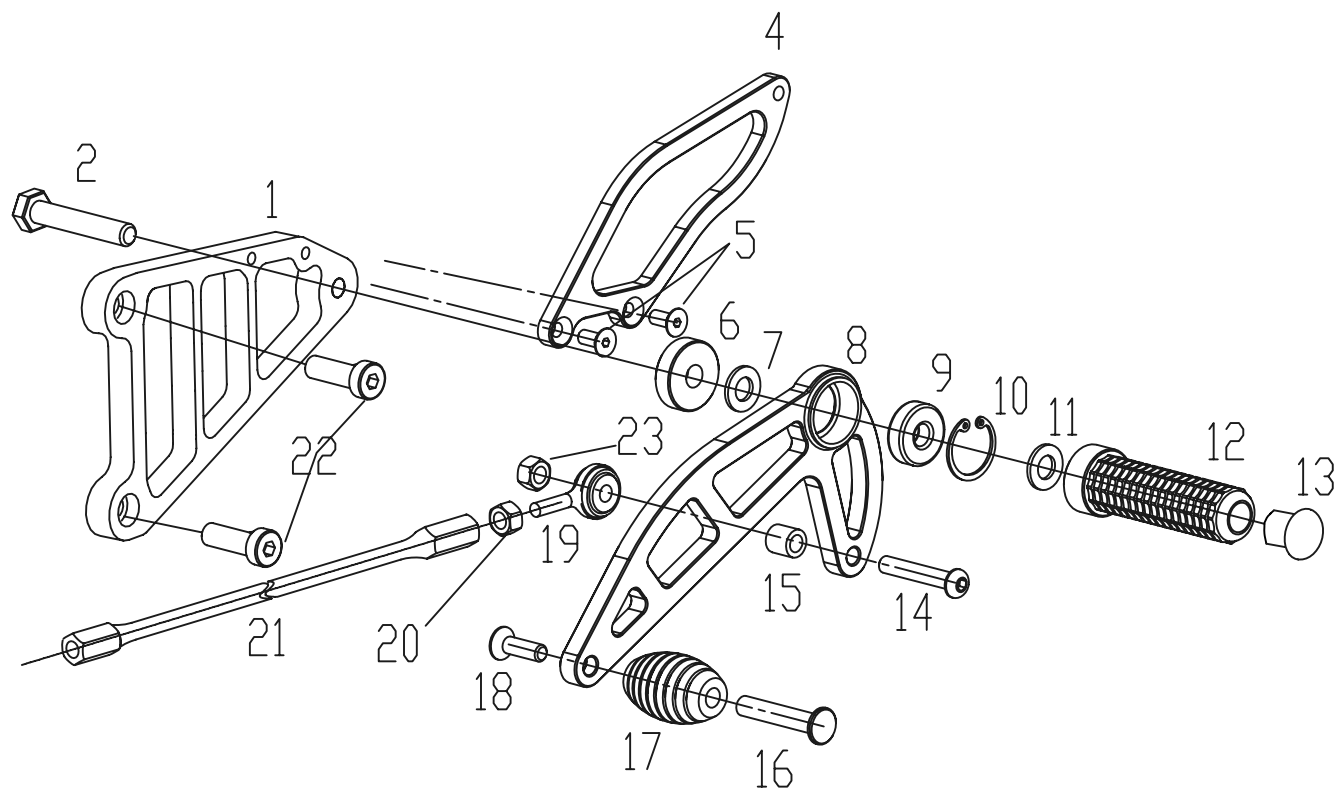

ZETASASSI
PARMA - ITALY

KAWASAKI 636 09 12

LATO CAMBIO

Pos.	descrizione	Qta'.
1	Poggiapiede	1
2	Rondella 8	1
3	Segger I22	1
4	Cuscinetto D22 L7 F8	1
5	Nottolino gommino	1
6	Gommino	1
7	Leva freno	1
8	Svasata 6x20	3
9	Ribassata 8x25	2
12	Esagonale 8x45	1
13	Nottolino per pompa M6 L=35	1
15	Porta pompa freno	1
16	Paratacco	1
18	Tonda 6x30	1
19	Distanziere D=24 L=7 foro=8,5	1
20	Rondella T02	1
21	Dado M6 autobloccante rib	1
22	Telaio	1
25	Tappo nylon	1
26	Tonda 8x30	2

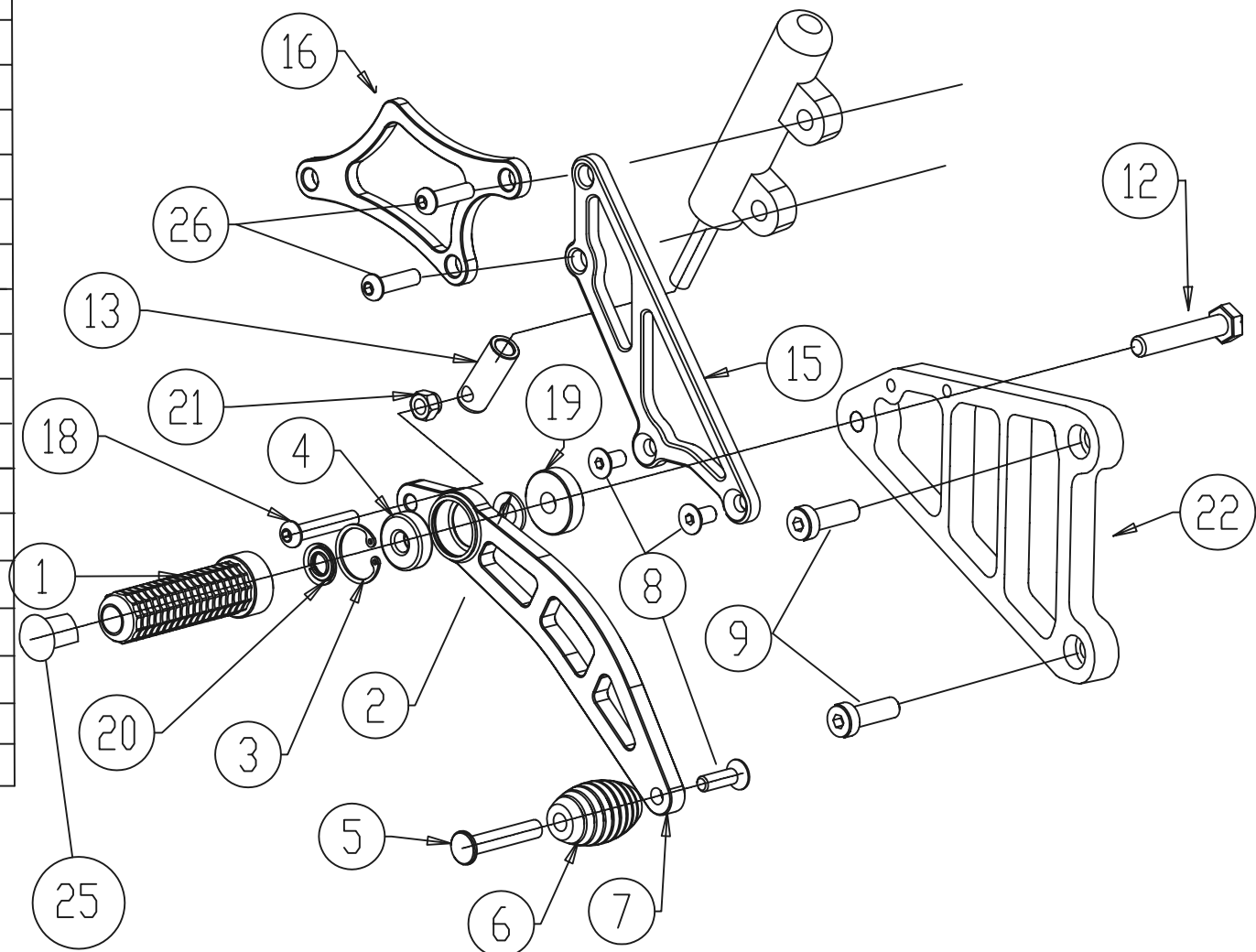

KAWASAKI 636 09 12
LATO FRENO

Pos.	descrizione	Qta'.
1	Poggiapiede dritto	1
2	Tappo nylon	1
3	Perno per coppiglia D8	1
4	Coppiglia	1
5	Telaio poggiapiede snodato	1
6	Rondella 8	1
7	Molla	1
8	Poggiapiede snodato	1

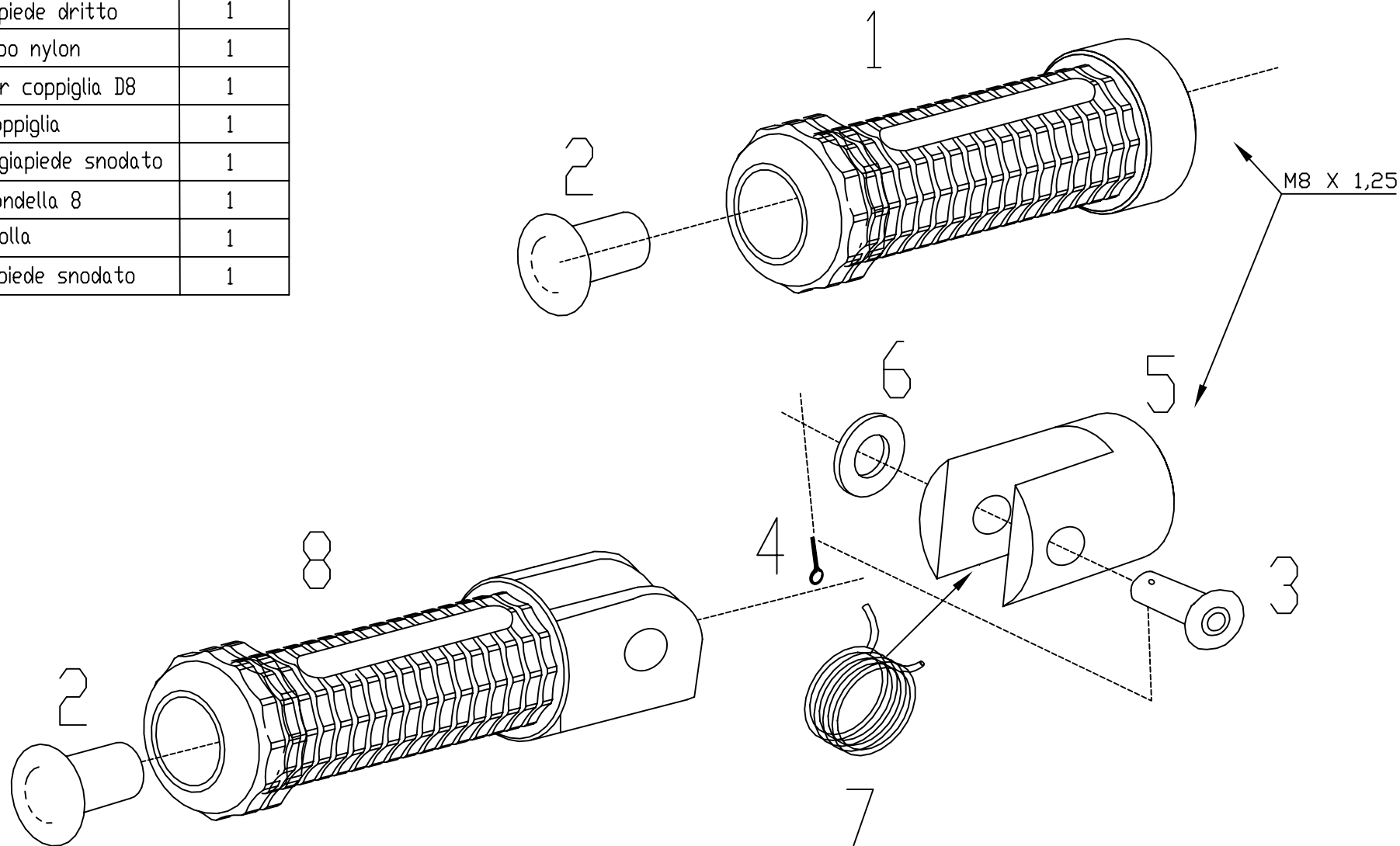

ZETASASSI
PARMA - ITALY

POGGIAPIEDI DRITTI E SNODATI

Pos.	descrizione	Qta'
1	Rondella T02	1 x Pz
2	Segger I22	1 x Pz
3	Cuscinetti D22 L7 F8	2 x Pz
4	Rondella 8	1 x Pz
5	Svasata 6x20	1 x Pz
6	Prolunga eccentrica GP	1 x Pz
7	Gommino	1 x Pz
8	Nottolino x gommino	1 x Pz
9	Leva freno GP	1
10	Leva freno 2 GP	1
11	Leva cambio GP	1
12	Brugola 5x15	1 x Pz

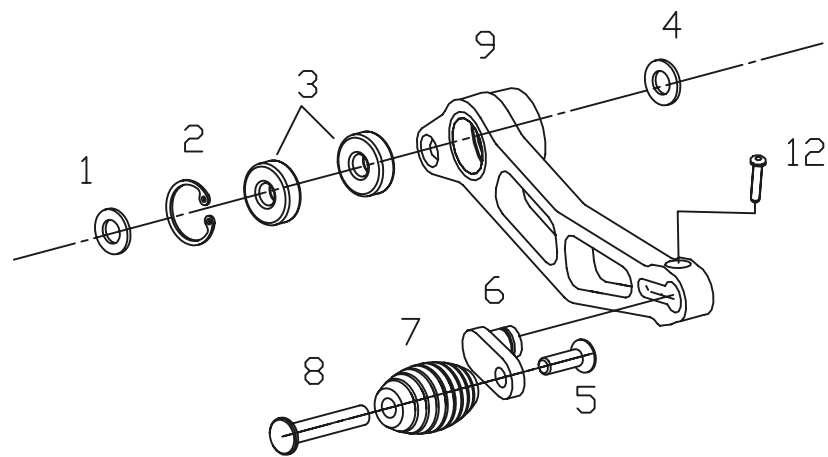

LEVA FRENO GP

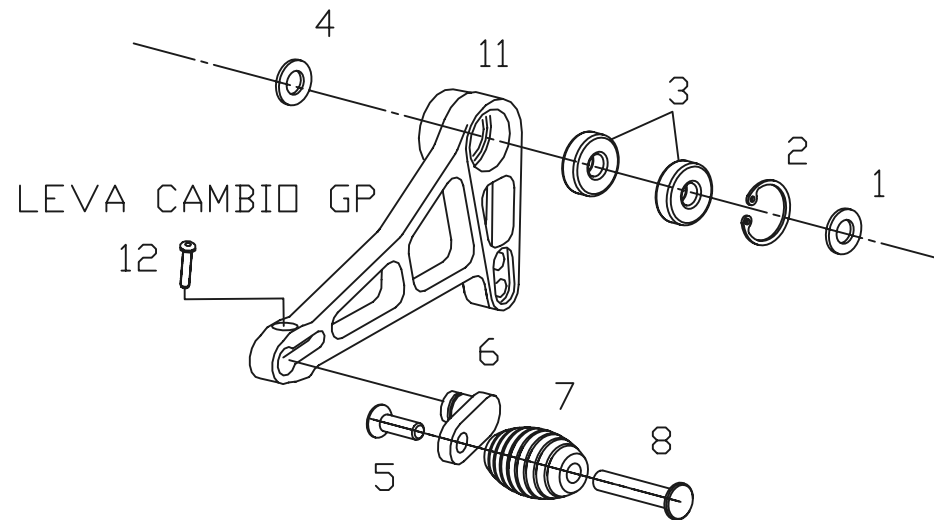

LEVA CAMBIO GP

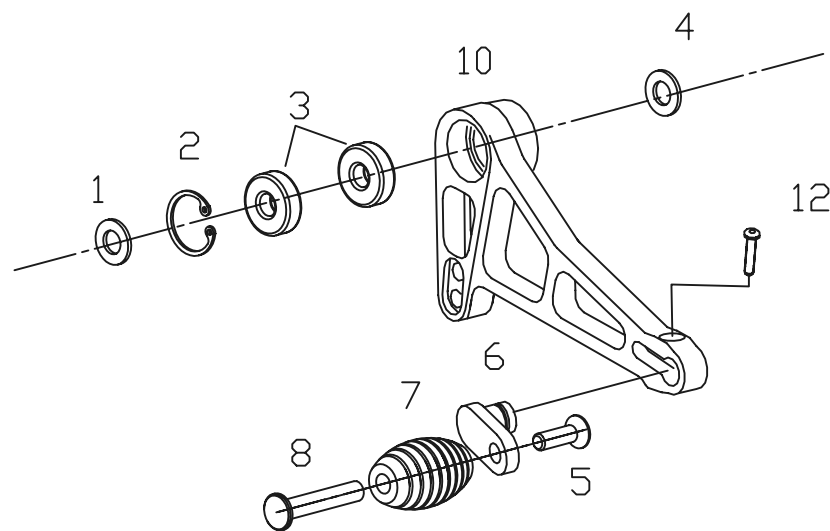

LEVA FRENO 2 GP



LEVE GP CAMBIO E FRENO